



Forture Tools
Abrasive Tools Specialist



Super Abrasives

Zhengzhou Forture Tools Co., Ltd.



abrasive@ftm96.com



+8613733809594



10 Dongqing Street,
Zhengzhou, Henan, China

Electroplated Tools For Optical



Optical Glass Wheel



Pencil Wheel



Cylinder Wheel



Forming Wheel



Glass Edging Wheel



Grooving Wheel



Multi-grooving Wheel



Edging Wheel



Cutting Wheel



Mounted Points



Carving Tools



Other Tools

The electroplated optical glass grinding wheel adopts high-quality diamond as the abrasive, and cooperates with the domestic advanced electroplating process to produce high-quality products, which has the characteristics of no chipping and smooth grinding surface. The electroplated optical grinding wheel adopts single-layer or double-layer sanding, which has the advantages of high grinding efficiency and low heat generation, and has a great effect on the shape and performance protection of the workpiece.



abrasive@ftm96.com



+8613733809594



10 Dongqing Street,
Zhengzhou, Henan, China

Electroplated Tools for Auto Parts



Hob Cutter Grinding Wheel

Being used for precision gears and turbine hobs for machining high speed steel and carbide materials.



Grinding wheel for groove

Groove grinding wheel is mainly used for the slotting of precision bows and arrows.



Wheels for Brake Pads

For external & internal arc grinding, surface grinding, chamfer grinding and grooving of drum brake pads and disc brake pads.



Screw Rotor Grinding Wheel

For machining spur gears and helical gears, It can be matched with CNC gear grinding machines at home and abroad.



Valve Processing Wheel

It is used for forming grinding of the engine valve lock groove, neck, disc taper, disc outer circle, disc end face, etc., and cutting of the rod end and multi-part combination processing.



Worm Grinding Wheel

This product is developed into a continuous indexing in the movement, so the grinding teeth have high production efficiency and high precision of the teeth.

Other diamond and CBN tools for automotive parts can be customized.



abrasive@ftm96.com



+8613733809594



10 Dongqing Street,
Zhengzhou, Henan, China

Metal Bond Grinding Wheels



Glass Grinding Wheels



Round Edge Wheels



CBN Grinding Wheels

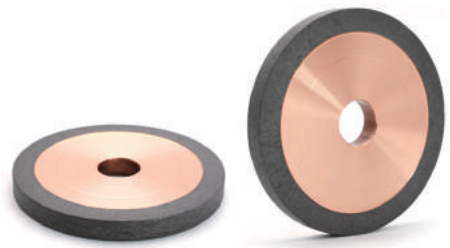

Slotting Wheels



Cylinder Wheels



Dressing Wheels



Glass Milling Wheels

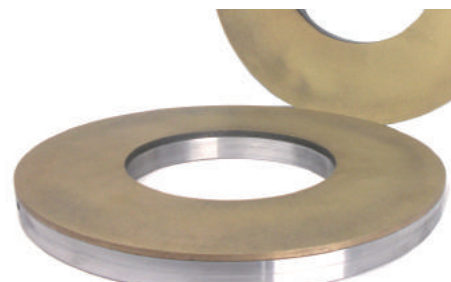

Surface Grinding Wheels



Welding Wheel

Metal Bond Diamond Grinding wheels are mainly used for machining quartz crystal, tungsten carbide, ceramics, glass, composite, sapphire, ferrite, refractory, thermal spraying materials and so on. Metal Bond CBN Grinding Wheels are mainly used for machining high speed steel, tool steel, mould steel, titanium alloy and so on.



abrasive@ftm96.com



+8613733809594



10 Dongqing Street,
Zhengzhou, Henan, China

Resin Bond Grinding Wheels

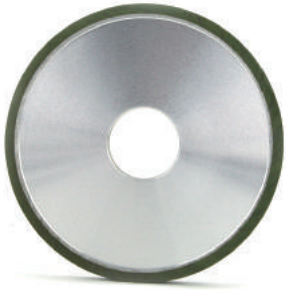

Plain Wheel



Flaring Cup Wheel



Bowl Shape Wheel



HSS Sharpening Wheel



Carbide Sharpening Wheel



Cylinder Wheel



Cup Wheel

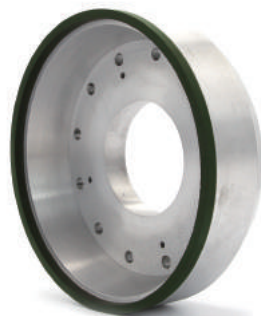

Silicon Wafer Wheel



Resin Diamond Disc

Resin Bond Diamond Grinding Wheels are mainly used for machining tungsten carbide, ceramic materials, magnetic materials, silicon materials, thermal spraying alloy materials and so on.
Resin Bond CBN Grinding Wheels are mainly used for machining high speed steel, cast iron and so on.



abrasive@ftm96.com



+8613733809594



10 Dongqing Street,
Zhengzhou, Henan, China

Vitrified Grinding Wheels

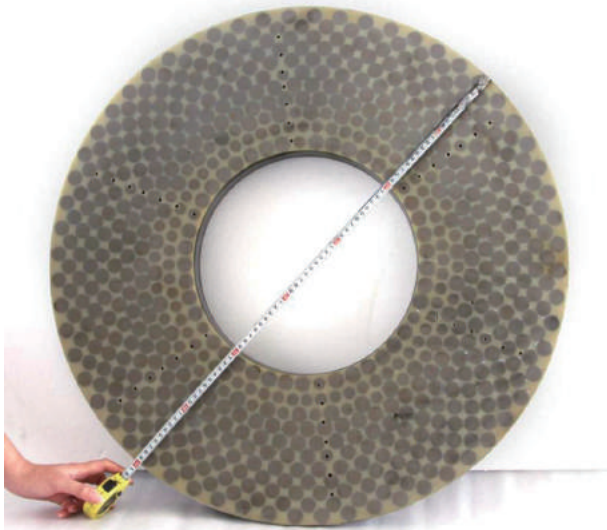

Surface Grinding Wheel



Surface Grinding Wheel



Internal Grinding Wheel



Vitrified Diamond Wheel

Vitrified Diamond Grinding Wheels are mainly used for machining tungsten carbide, PCD, PCBN, ceramic, cermet, etc.

Vitrified CBN Grinding Wheels are mainly used for machining cast iron(alloy cast iron, chilled cast iron, nodular cast iron, etc.) steel(45#,55#,20Cr.etc.)



abrasive@ftm96.com



+8613733809594



10 Dongqing Street,
Zhengzhou, Henan, China

Diamond Dressing Tools

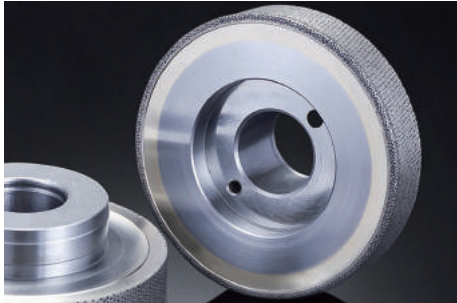

Diamond Rotary Dresser



Sintering Rotary dresser



Electroplated Rotary Dresser

Diamond rotary dresser is a rotary body by powder metallurgy or is coated on the surface of a layer of consolidation diamond, and the diamond layer to form a desired Precision Truing of grinding wheel surface dressing tools.

With the rapid development of mechanical industry, some industries (such as automobile and its parts manufacturers) the constant pursuit of production scale, product standard which requires grinding processing of industrial products must be toward high efficiency, high accuracy and low cost development.

Diamond rotary dresser's applications become more and more widely under this kind of industrial requirement. Corresponding to the traditional dressing, such as single point dressing, press dressing, diamond rotary dresser is showing more and more wide application prospect and field with above advantages.



Multi-point Diamond Dresser



Single-point Diamond Dresser

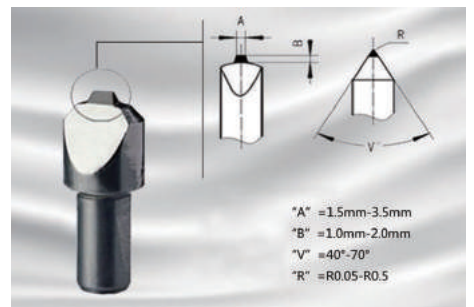

A =1.5mm-3.5mm
 B =1.0mm-2.0mm
 V =40°-70°
 R =R0.05-R0.5

Formed Diamond Dresser

Diamond Dressers are made with natural diamond and synthetic materials like CVD, PCD and MCD. in steel shanks of various shapes for straight or form dressing. For truing and dressing of conventional abrasive grinding wheels. It is including Single-point, multi-point, chisel shape, straight, angle, and radius configurations. They are used for improving abrasive grinder performance by helping round the wheel and clean, shape or open the wheel face.



abrasive@ftm96.com



+8613733809594



10 Dongqing Street,
 Zhengzhou, Henan, China

Grinding Wheels' Dimension

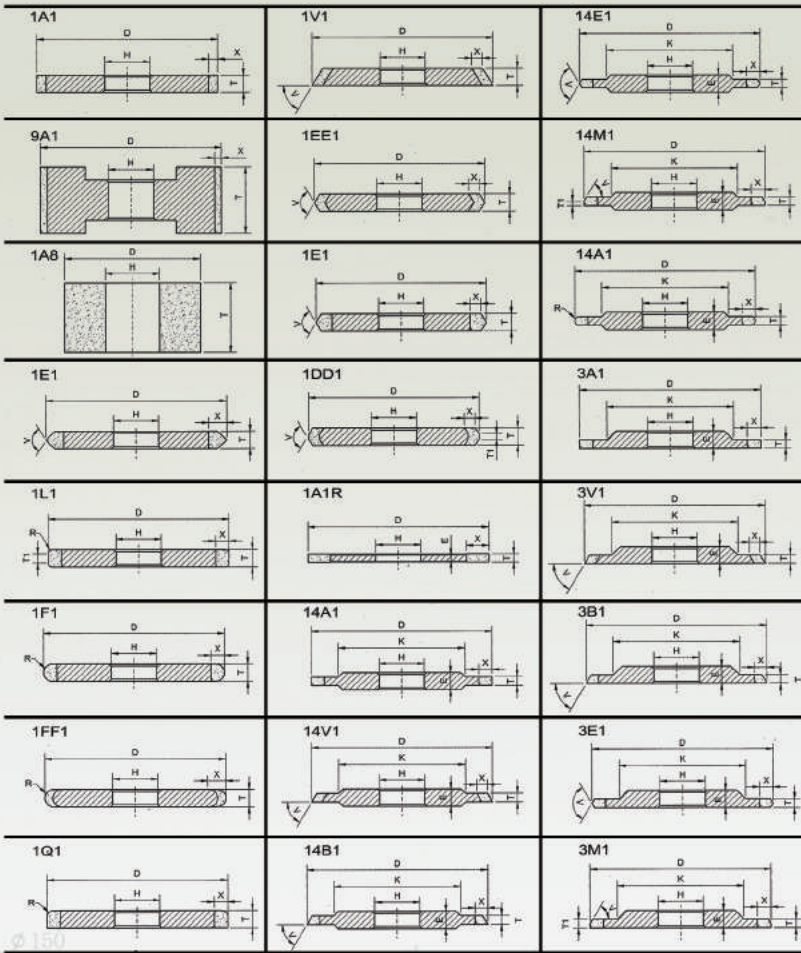

Diamond, CBN grinding wheels' writing format

11V9_(v:70°)

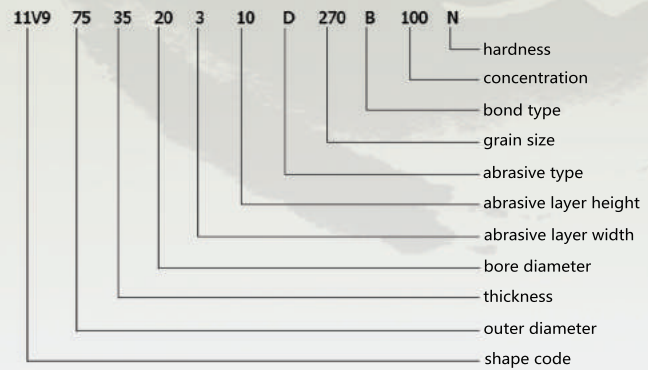

Corresponding relations between abrasive grit option and workpiece's roughness

Grinding process	Grit		Workpiece surface roughness	
	Old standard	New standard	Old standard	New standard
Rough grinding	70#~100#	60/70#~100/120#	△6~8	Ra3.2~0.8
semi-finishing	100#~180#	100/120#~200/230#	△8~9	Ra0.8~0.4
finishing	180#~W40	200/230#~36~54#	△9~10	Ra0.4~0.2
Grinding and polishing	W40~W1	36/54#~W0.5~1	△10~12	Ra0.42~0.05

